

USER MANUAL

UOHC

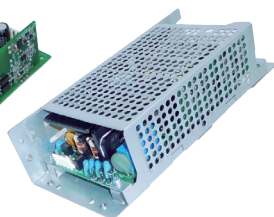

UOHC 3150

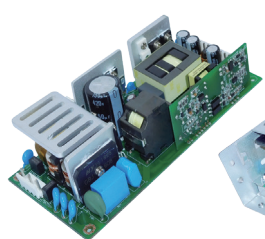
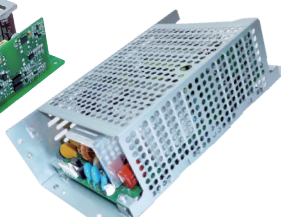
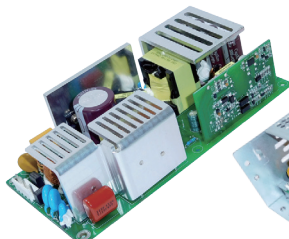

UOHC 3240

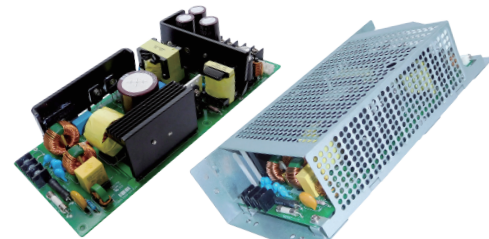

UOHC 3300

UOHC Series

1 Function Definition .. 1 - 3

- 1.1 - Input Voltage Range
- 1.2 - Inrush Current
- 1.3 - Overcurrent Protection
- 1.4 - Overvoltage Protection
- 1.5 - Output Ripple & Noise
- 1.6 - Isolation
- 1.7 - Reducing Standby Power
- 1.8 - Output Voltage Adjustment Range
- 1.9 - Peak Load

3 Instructions 8 - 10

- 3.1 - Option Description
- 3.2 - -R 、-CR : Remote ON/OFF function
- 3.3 - Increase output
- 3.4 - Series Operation / Parallel Operation
- 3.5 - External Use Of Capacitor On Output Side

2 Installation 3 - 7

- 2.1 - Installation Method
- 2.2 - Mounting Screw
- 2.3 - Ground
- 2.4 - Mounting Direction and Method
- 2.5 - Derating Curve & Temperature
- 2.6 - Temperature Measurement Point

4 Life Expectancy & Warranty ... 11

5 Cautions 12

1. Function Definition

1.1 - Input Voltage Range

- The range is from 85VAC to 264VAC. In cases that comply with safety standard, input voltage range is 100VAC to 240VAC (50/60Hz). Appendix 8 of PSE comply with 100VAC 50/60 Hz . When using with DC input, in order to provide safe protection when the power fails, please choose a DC power supply product with protection function or install DC fuse for protection. For detail information please contact us.
- If input doesn't fall within above range, please note that it may cause operation that does not meet the specifications - repeated starting or fail. If you need the square waveform input voltage which is commonly used in UPS and inverters, please contact us.
- When the input voltage changes suddenly, the output voltage accuracy might exceed the specification. If the restart time of the short interruption power failure is less than 3 seconds, perform a thorough evaluation.
- Supports instantaneous input voltage sag, the output load reference is as follows: doesn't support Input Voltage AC 100VAC->50VAC , support input voltage AC 200VAC->100VAC, output load 100%.

1.2 - Inrush Current

- An inrush current limiting circuit is built-in.
- If using a switch or similar device on the input side, please select one that can withstand an input inrush current.
- To prevent inrush current, please wait more than 3 seconds before turning on.

1.3 - Overcurrent Protection

- An overcurrent protection circuit is built-in (operating above 101% of the peak current.) If the overcurrent abnormality is eliminated, please connect the power again and the output voltage will return to normal.
- Latching overcurrent mode:
When overcurrent occurs, the output state is completely shut down, which can more safely protect the customer's device and personal safety.
- Please avoid use in short-circuit or over-current mode for long time.

1.4 - Overvoltage Protection

- An overvoltage protection circuit is built-in. After activating the overvoltage protection circuit, if the factors causing the abnormal phenomenon have been removed, please turn off the input voltage and apply the input voltage again, and the output voltage will recover.
- Remote release option: Select -R or -CR, remote control ON/OFF can be used to release overvoltage protection.
- Caution : When a voltage higher than the rated voltage which is applied to the output terminal from the outside, it may cause fail or malfunction, so please avoid this action.
If this possibility cannot be avoided when using motor load... etc., please contact us.

1.5 - Output Ripple & Noise

- Output ripple noise may be influenced by measurement environment, the below measuring method is recommended as the picture [1.5.1](#).
- If the output ripple & noise are test by an oscilloscope, the power supply generates magnetic flux that passes through the GND line loop of the measuring probe tip, ripple & noise might not measure correctly. In addition, please keep sufficient distance between input and output wires in order to reduce the influence of the above magnetic flux when using the power supply, and spiral wire type is recommended.

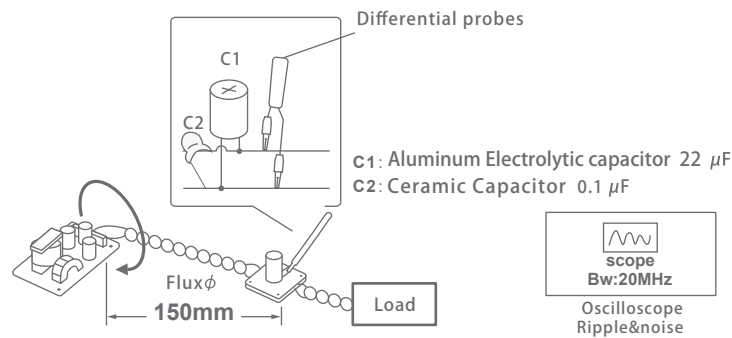

1.5.1 UOHC | Example of measuring output ripple & noise

1.6 - Isolation

- When conducting the inspection, gradually increase the voltage. After the test is completed, please also slowly decrease the voltage.
- When choosing -CR product, please short-circuit the output terminal, 5V output terminal and RC terminal when testing between input-output, input-FG and output-FG.
- When choosing -CS product, please short-circuit the output terminal, 5V output terminal when testing between input-output, input-FG and output-FG.

1.7 - Reducing Standby Power

- There is a built-in function to reduce power consumption during standby. At light load, the internal switch element is operated in burst mode to reduce switching power supply loss. This may cause the specifications of ripple & noise to change.

1.8 - Output Voltage Adjustment Range

- The output voltage can be adjusted through a variable resistor of the output voltage.
- To increase an output voltage, turn the variable resistor clockwise.

1.9 - Peak Load

- Peak load is shown as below 1.9.1
- Peak load current I1 , should lower than peak current and the duty less than 50.

$$t_1 \leq 10 \text{ [sec]}, \quad \text{Duty} = \frac{t_1}{t_1 + t_2} \leq 50, \quad I_1 \leq \text{peak current}$$

It is not recommended that the peak load duration exceeds the specified duty cycle calculation value, as it may cause damage to the power supply. If the application range exceeds the above calculated value, please contact us.

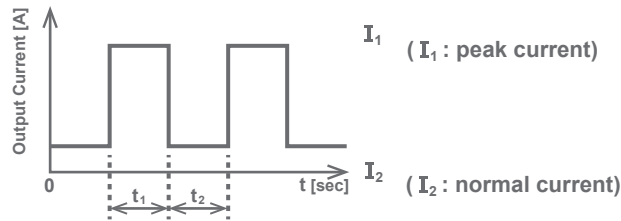

1.9.1 PEAK Current Diagram

2. Installation

2.1 - Installation Method

Open Frame

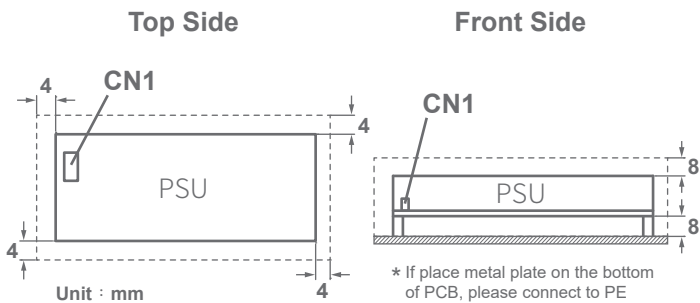

2.1.1 The installation distance of open frame

Enclosed Type

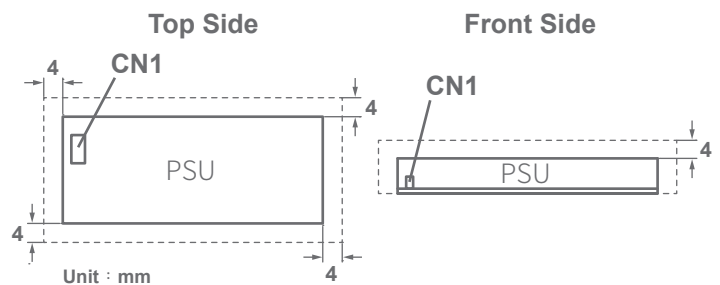

2.1.2 The installation distance of enclosed type

For safety reasons, please ensure the mounted device is kept at a safety distance as below at all sides from other components and equipments.

- Open frame ≥ 8 mm from primary side ≥ 4 mm from secondary side.
- Enclosed Type ≥ 4 mm

There is a possibility that power supply is not possible to cool enough when the it is used in the sealing up space as showing as below picture.

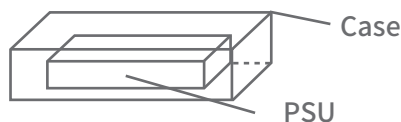

2.1.3 The picture of power supply with case

2.2 - Mounting Screw

- Please use M3 screws for mounting.
- The shaded area in picture 2.2.1 2.2.2 below is the range of ground.
- Please refer to the diagram below to ground, fix the mounting holes and connect the mounting holes to the ground.
- Please note that the standard shock resistance specifications are based on using 8mm height.
- The copper foil for PCB grounding is 8*8mm.

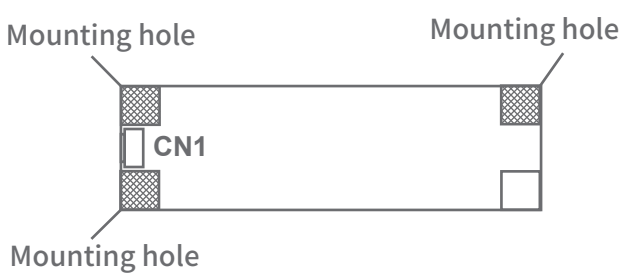

2.2.1 UOHC 3150 & UOHC 3240 | Mounting hole



2.2.2 UOHC 3300 | Mounting hole

2.3 - Ground

- The below three methods can be used:
 - ① FG pin of CN1 connected to ground.
 - ② Mounting holes connected to ground.
 - ③ The system case connected to ground.

2.4 - Mounting Direction and Method

- The installation as below, (A) is recommended. (B)~(F) are also applicable. Please do not install with other directions.

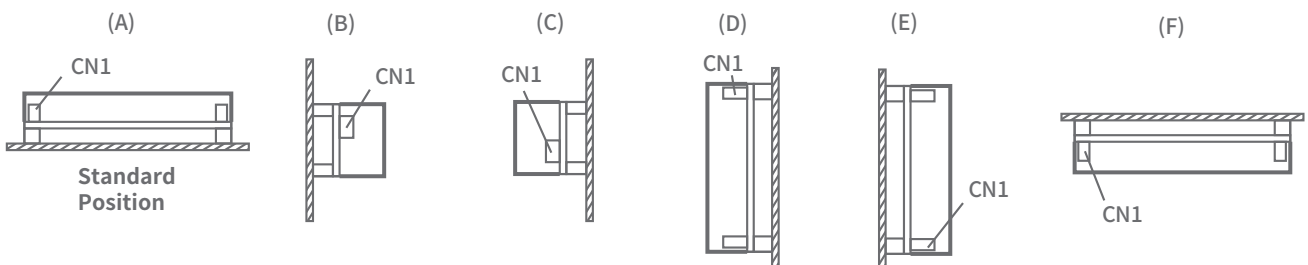

2.4.1 Mounting direction

- Do not twist or bend the printed circuit board since SMD components were soldered on it.
- All mounting holes must be fixed.
- Please install the printed circuit board parallel to the mounting surface.
- Do not drop the product.

■ Forced Cooling

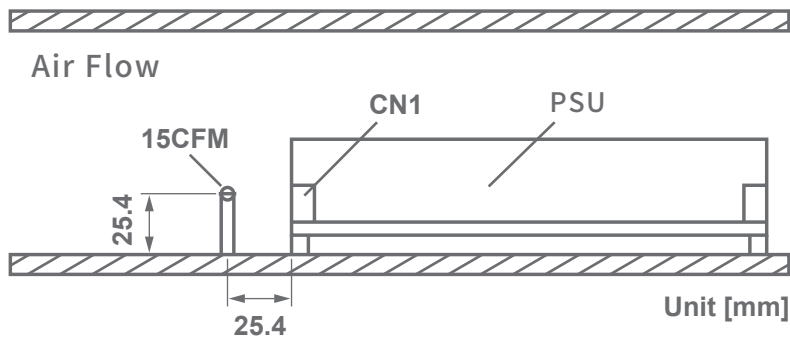

2.4.2 The schematic diagram of air flow

2.5 - Derating Curve & Temperature

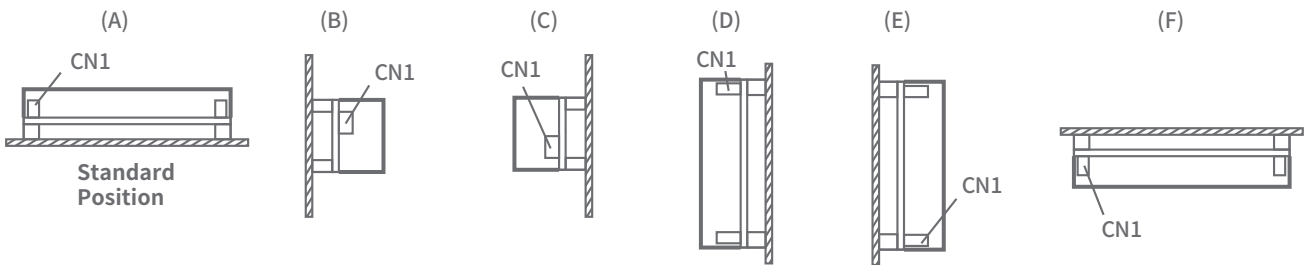

2.5.1 Mounting direction

■ Mounting direction output derating curve

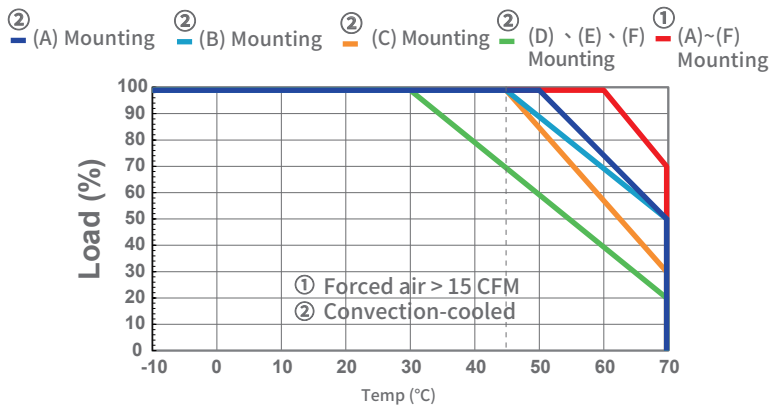

2.5.2 UOHC3150 | Mounting direction output derating curve

■ Input voltage & derating

It requires derating while input voltage lower than 90VAC.

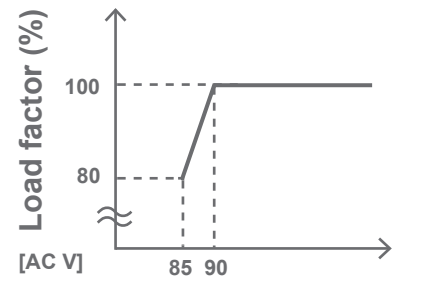

2.5.3 UOHC3150 | Input derating curve

■ Mounting direction output derating curve

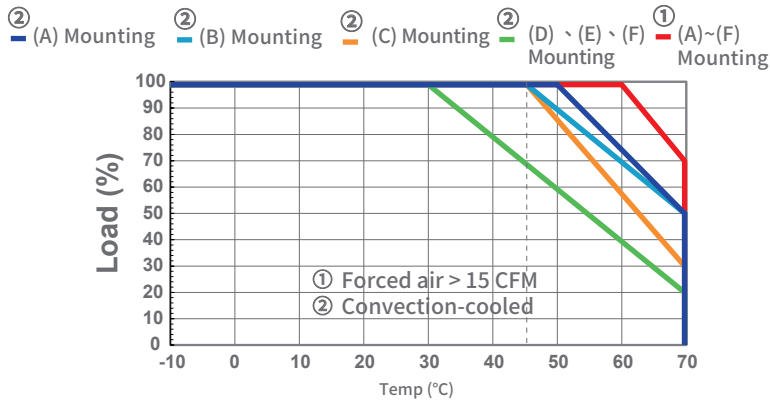

2.5.4 UOHC3240 | Mounting direction output derating curve

■ Input voltage & derating

It requires derating while input voltage lower than 90VAC.

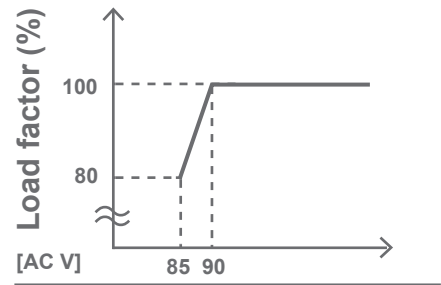

2.5.5 UOHC3240 | Input derating curve

■ Mounting direction output derating curve

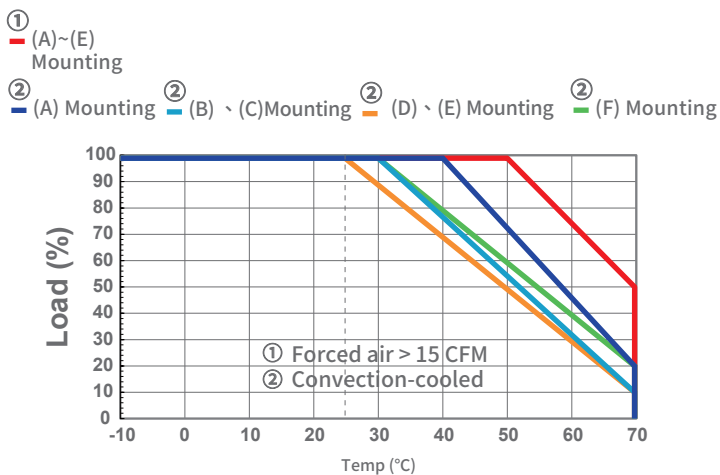

2.5.6 UOHC3300 | Mounting direction output derating curve

■ Input voltage & derating

It requires derating while input voltage lower than 90VAC.

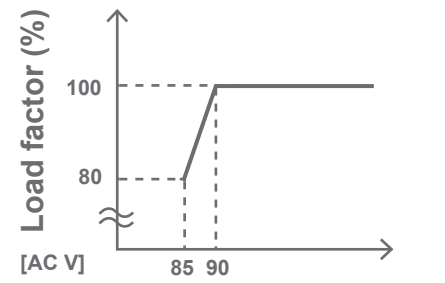

2.5.7 UOHC3300 | Input derating curve

2.6 - Temperature Measurement Point

- When using equipment must consider the power supply to cooling.
- The picture below shows the relationship between the upper temperature limitation and load of points (A) and (B). In order to allow the entire power supply to have sufficient ventilation, it is necessary to consider the conditions of the wind, and ensuring that the temperatures at points (A) and (B) must be below the specified upper limit.
- When operating at the maximum temperature limit of points (A) and (B), the life expectancy is more than 3 years.
- Points (A) and (B) are conductive parts. When measuring temperature, be careful to electric shock and leakage. Please contact us for details.
- Point A、B are as below.
- Please refer to the following picture for setting method & conditions.

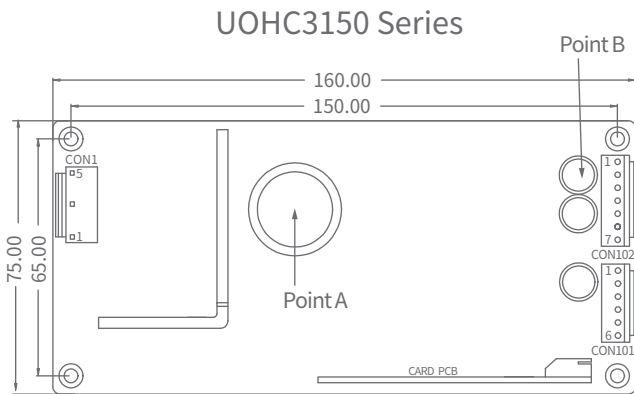

Point A、Point B are the temperature measurement point

2.6.1 UOHC3150 | Temperature measurement point

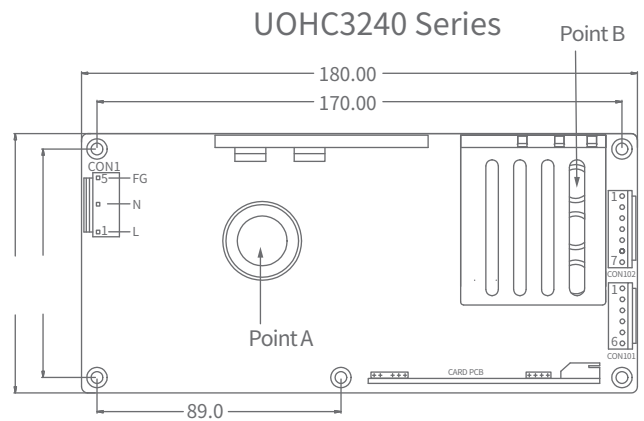

Point A、Point B are the temperature measurement point

2.6.2 UOHC3240 | Temperature measurement point

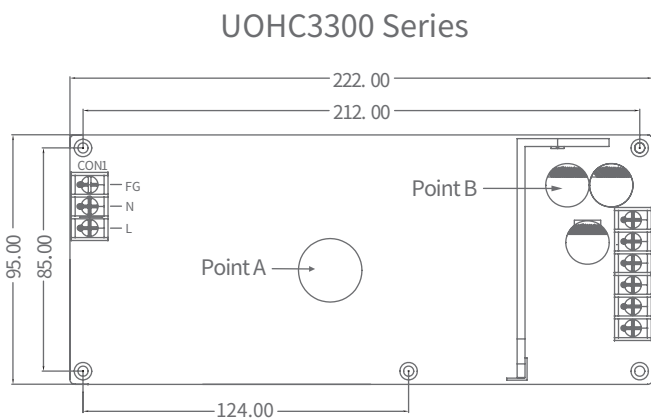

2.6.3 UOHC3300 | Temperature measurement point

Mounting Method	Cooling Method	Load factor	Max temperature	
			Point A(°C)	Point B(°C)
A	Convection	75% < I o ≤ 100%	73	72
		50% < I o ≤ 75%	77	75
		0% < I o ≤ 50%	82	80
B	Convection	75% < I o ≤ 100%	70	70
		50% < I o ≤ 75%	75	75
		0% < I o ≤ 50%	80	80
C	Convection	75% < I o ≤ 100%	70	70
		50% < I o ≤ 75%	75	75
		0% < I o ≤ 50%	80	80
D	Convection	75% < I o ≤ 100%	70	70
		50% < I o ≤ 75%	75	75
		0% < I o ≤ 50%	80	80
E	Convection	75% < I o ≤ 100%	70	70
		50% < I o ≤ 75%	75	75
		0% < I o ≤ 50%	80	80
F	Convection	75% < I o ≤ 100%	70	70
		50% < I o ≤ 75%	75	74
		0% < I o ≤ 50%	85	83
A,B,C, D,E,F	Forced air	70% < I o ≤ 100%	68	68
		0% < I o ≤ 70%	68	68

Mounting Method	Cooling Method	Load factor	Max temperature	
			Point A(°C)	Point B(°C)
A	Convection	75% < I o ≤ 100%	80	89
		50% < I o ≤ 75%	83	89
		0% < I o ≤ 50%	87	92
B	Convection	75% < I o ≤ 100%	85	82
		50% < I o ≤ 75%	87	86
		0% < I o ≤ 50%	91	91
C	Convection	75% < I o ≤ 100%	74	75
		50% < I o ≤ 75%	76	78
		0% < I o ≤ 50%	79	80
D	Convection	75% < I o ≤ 100%	57	58
		50% < I o ≤ 75%	64	64
		0% < I o ≤ 50%	72	72
E	Convection	75% < I o ≤ 100%	57	82
		50% < I o ≤ 75%	62	79
		0% < I o ≤ 50%	70	83
F	Convection	75% < I o ≤ 100%	64	71
		50% < I o ≤ 75%	68	74
		0% < I o ≤ 50%	75	79
A,B,C, D,E,F	Forced air	70% < I o ≤ 100%	66	69
		0% < I o ≤ 70%	43	46

2.6.3 UOHC3150

Temperature measurement point and capacitor temperature

2.6.4 UOHC3240

Temperature measurement point and capacitor temperature

Mounting Method	Cooling Method	Load factor	Max temperature	
			Point A(°C)	Point B(°C)
A	Convection	75% < I o ≤ 100%	80	92
		50% < I o ≤ 75%	71	75
		0% < I o ≤ 50%	68	69
B	Convection	75% < I o ≤ 100%	71	84
		50% < I o ≤ 75%	66	72
		0% < I o ≤ 50%	62	64
C	Convection	75% < I o ≤ 100%	76	85
		50% < I o ≤ 75%	67	72
		0% < I o ≤ 50%	54	54
D	Convection	75% < I o ≤ 100%	77	81
		50% < I o ≤ 75%	75	80
		0% < I o ≤ 50%	69	67
E	Convection	75% < I o ≤ 100%	70	98
		50% < I o ≤ 75%	70	90
		0% < I o ≤ 50%	63	74
F	Convection	75% < I o ≤ 100%	91	96
		50% < I o ≤ 75%	80	82
		0% < I o ≤ 50%	70	67
A	Forced air	70% < I o ≤ 100%	51	77
		0% < I o ≤ 70%	47	63
B	Forced air	70% < I o ≤ 100%	48	72
		0% < I o ≤ 70%	45	60
C	Forced air	70% < I o ≤ 100%	51	71
		0% < I o ≤ 70%	41	56
D	Forced air	70% < I o ≤ 100%	54	74
		0% < I o ≤ 70%	45	60
E	Forced air	70% < I o ≤ 100%	42	64
		0% < I o ≤ 70%	47	61
F	Forced air	70% < I o ≤ 100%	55	77
		0% < I o ≤ 70%	51	63

2.6.4 UOHC3300

Temperature measurement point and capacitor temperature

3. Instructions

3.1 - Option Description

- -N : Standard
- -S : Increase Output
- -R : Remote Control and Increase Output
- -CN : Chassis and Cover
- -CS : Chassis and Cover with Increase Output
- -CR : Chassis and Cover with Remote Control and Increase Output

3.2 - -R 、 -CR : Remote ON/OFF function

- You can remotely control by external DC power supply. Follow these methods as below.

———— The output is turn ON/OFF by PS_ON signal ————

PS_ON	Action	Level
Low	Turn off output	0-0.5V
High	Turn on output	4.5V-12.6V

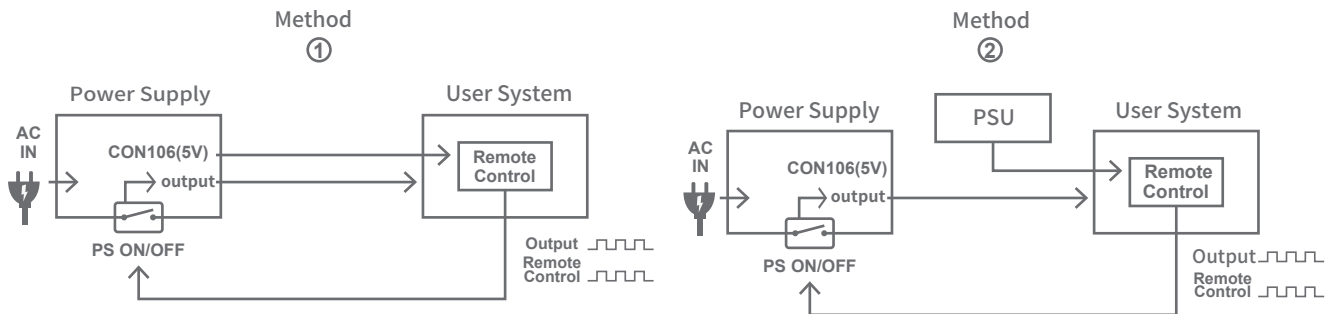

3.2.1 UOHC3150 &UOHC3240 | The example of remote ON/OFF

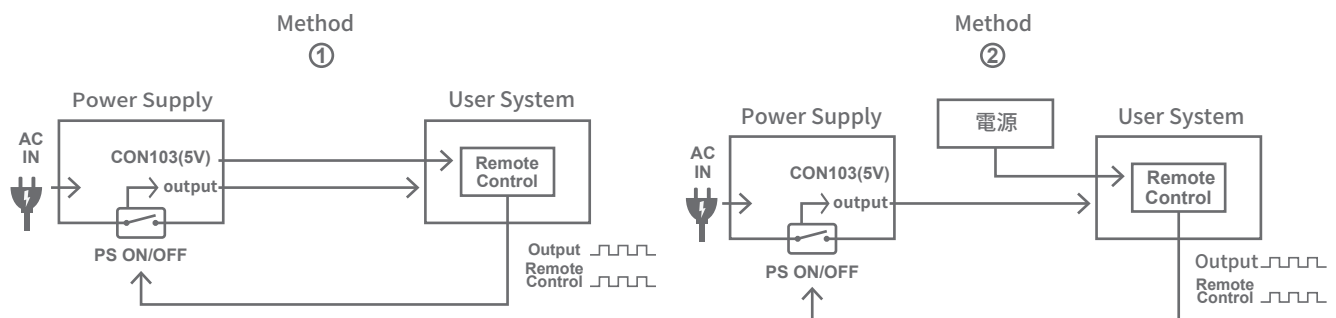

3.2.2 UOHC3300 | The example of remote ON/OFF

- Reverse connections may damage internal components.

3.3 - Increase Output

- UOHC3150 & UOHC3240:
There is a built-in set of 5 V/1 A extra power supply for the device, using the CON106 connector. Once the AC input is powered on, the output starts. add an extra set output power can be applied.
- UOHC3300:
There is a built-in set of 5 V/2 A extra power supply for the device, using the CON103 connector. Once the AC input is powered on, the output starts. add an extra set output power can be applied.

3.4 - Series Operation / Parallel Operation

Series Operation

- Please note that the output current must less or equal to rated current ' and cannot exceed the rated current. The example of series operation is shown in picture 3.4.1.
- The rated current of the bypass diode must more than or equal to the load current, and the reverse rated withstand voltage must be higher than the power supply output voltage.

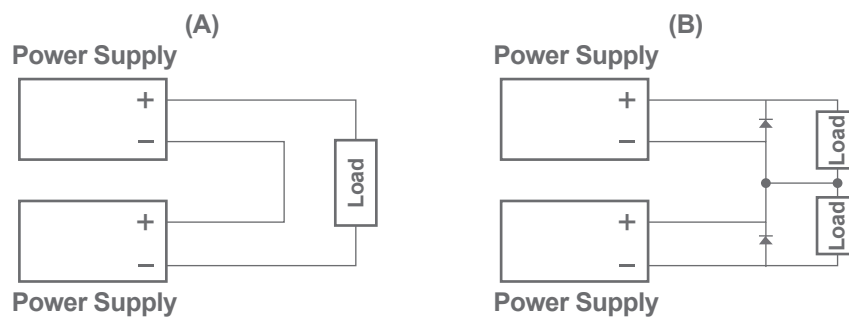

3.4.1 The example of series operation & parallel operation

Parallel Operation/Long-term Operation

- Can be used as a backup power to connect.
- The output voltage and output power of the power supply should comply with the specification values. The connection for long-term operation are shown as picture 3.4.2.
- Slightly differences in output voltage may cause unbalanced of I1 and I2 values. Make sure that the value of I3 does not exceed the rated current of a power supply. $I3 \leq \text{Rated current}$.

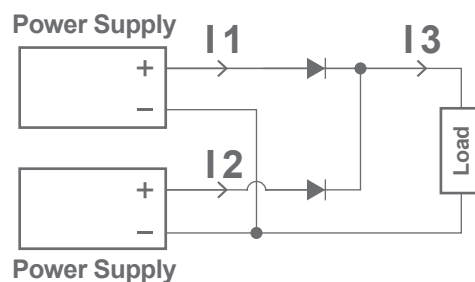

3.4.2 The example of parallel operation/long-term operation

3.5 - External use of capacitor on output side

- The size of the additional capacitor, ESR, ESL and wiring inductance may cause resonance and ripples.
- If the external capacitor capacity is too large, the output voltage may not start normally. Please refer to the following picture for the maximum allowable external capacitor capacity.

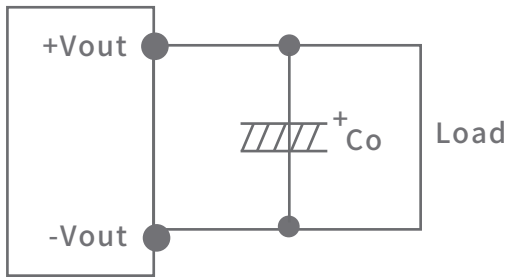

Output Voltage	Capacitance(μ F)
24V	6000 μ F

3.5.1 The example of connect an external capacitor to the output

3.5.2 UOHC3150 | External use of load capacitor on output side

Output Voltage	Capacitance(μ F)
24V	6000 μ F

Output Voltage	Capacitance(μ F)
24V	6000 μ F

3.5.3 UOHC3240 | External use of load capacitor on output side

3.5.4 UOHC3300 | External use of load capacitor on output side

4. Life Expectancy / Warranty

UOHC3150

■ Life Expectancy

Mounting Method	Cooling Method	Average ambient temperature(year)	Life Expectancy	
			$l_o \leq 75\%$	$75\% < l_o \leq 100\%$
A	Convection	Ta = 40°C or less	10years	10 years
		Ta = 50°C	10years	8 years
B	Convection	Ta = 35°C or less	10years	10 years
		Ta = 45°C	10years	10years
C	Convection	Ta = 35°C or less	10years	10years
		Ta = 45°C	10years	6 years
D,E,F	Convection	Ta = 20°C or less	10years	10 years
		Ta = 30°C	10 years	10 years
A,B,C, D,E,F	Forced air	Ta = 60°C	5years	3years

4.1.1 Life Expectancy

■ Warranty

Mounting Method	Cooling Method	Average ambient temperature(year)	Warranty	
			$l_o \leq 75\%$	$75\% < l_o \leq 100\%$
A	Convection	Ta = 40°C	5years	5years
		Ta = 50°C	5years	3years
B	Convection	Ta = 35°C	5years	5years
		Ta = 45°C	5years	3years
C	Convection	Ta = 35°C	5years	5years
		Ta = 45°C	5years	3years
D,E,F	Convection	Ta = 20°C	5years	5years
		Ta = 30°C	5years	3years
A,B,C, D,E,F	Forced air	Ta = 60°C	5years	3years

4.1.2 Warranty

UOHC3240

■ Life Expectancy

Mounting Method	Cooling Method	Average ambient temperature(year)	Life Expectancy	
			$l_o \leq 75\%$	$75\% < l_o \leq 100\%$
A	Convection	Ta = 40°C or less	10years	10 years
		Ta = 50°C	8 years	5 years
B	Convection	Ta = 35°C or less	10years	10 years
		Ta = 45°C	9 years	6 years
C	Convection	Ta = 25°C or less	10years	10years
		Ta = 35°C	10years	6 years
D,E	Convection	Ta = 20°C or less	10years	10years
		Ta = 30°C	10years	8 years
F	Convection	Ta = 25°C or less	10years	10years
		Ta = 15°C	10years	10years
A,B,C, D,E,F	Forced air	Ta = 60°C	5 years	3 years

4.1.3 Life Expectancy

■ Warranty

Mounting Method	Cooling Method	Average ambient temperature(year)	Warranty	
			$l_o \leq 75\%$	$75\% < l_o \leq 100\%$
A	Convection	Ta = 40°C	5 years	5 years
		Ta = 50°C	5 years	3 years
B	Convection	Ta = 35°C	5 years	5 years
		Ta = 45°C	5 years	3 years
C	Convection	Ta = 25°C	5 years	5 years
		Ta = 35°C	5 years	3 years
D,E	Convection	Ta = 20°C	5 years	5 years
		Ta = 30°C	5 years	3 years
F	Convection	Ta = 25°C	5 years	5 years
		Ta = 15°C	5 years	5 years
A,B,C, D,E,F	Forced air	Ta = 60°C	5 years	3 years

4.1.4 Warranty

UHC3300

■ Life Expectancy

Mounting Method	Cooling Method	Average ambient temperature(year)	Life Expectancy	
			$l_o \leq 75\%$	$75\% < l_o \leq 100\%$
A	Convection	Ta = 30°C or less	10years	10 years
		Ta = 40°C	10years	10 years
B	Convection	Ta = 20°C or less	10years	10 years
		Ta = 30°C	10years	9 years
C	Convection	Ta = 20°C or less	10years	10years
		Ta = 30°C	10years	9 years
D,E	Convection	Ta = 25°C or less	10years	7 years
		Ta = 35°C	10years	7 years
A,B,C, D,E	Forced air	Ta = 50°C	5 years	3 years

4.1.5 Life Expectancy

■ Warranty

Mounting Method	Cooling Method	Average ambient temperature(year)	Warranty	
			$l_o \leq 75\%$	$75\% < l_o \leq 100\%$
A	Convection	Ta = 30°C	5 years	5 years
		Ta = 40°C	5 years	3 years
B	Convection	Ta = 20°C	5 years	5 years
		Ta = 30°C	5 years	3 years
C	Convection	Ta = 20°C	5 years	5 years
		Ta = 30°C	5 years	3 years
D,E	Convection	Ta = 20°C	5 years	3 years
		Ta = 30°C	5 years	3 years
A,B,C, D,E	Forced air	Ta = 50°C	5 years	3 years

4.1.6 Warranty

5. Cautions

- If there are any differences from the listed here, then based on the individual .
 - This product is an open frame power supply. When using it, please make sure that no conductive objects fall into the printed circuit board.
 - When the low load, high voltage may remain inside the power supply for several minutes after the input power is turned off. Please be careful not to touch it.
 - Do not touch this product immediately while it is power on or off, as it may result in burns or electric shock.
 - The SMD components were soldered on the printed circuit board. Twisting or bending the printed circuit board may cause product failure, so please operate with caution. When handling items, hold the board by its edges and avoid touching components.
 - Do not modify, disassemble or remove covers. Otherwise it may cause electric shock or fail. The manufacturer will not assume any responsibility after modification, alteration or disassembly.
 - Do not use this product under abnormal conditions and special environments, such as exposure under the sunlight, condensation, water, rain, strong electromagnetic fields or places and environments with corrosive gases (hydrogen sulfide, sulfur dioxide, etc.).
 - Do not use or store this product in an environment where moisture or condensation. It may result in electric shock or fire.
 - The noise of terminal voltage, noise intensity, and immunity are the results under the standard measurement conditions of UNIFIVE's products. The equipment's installation and wiring conditions may not meet standards. Please make a thorough evaluation of actual equipment before using the product. Please be sure to conduct the necessary testing for final product.
 - Make sure the input/output terminals and each signal terminal are wired correctly, as described in the user manual. Use this product within the specifications of the voltage, output current, output power, ambient temperature and humidity. Using the product beyond specifications may result in product damage and avoid overloading this product.
 - Use the shortest and thickest wires as possible.
 - When wiring the input and output terminals, disconnect power from the input terminals.
 - If the built-in fuse blows, do not replace the fuse and continue to use the device. An abnormality may have occurred within the device.
 - If the product hasn't been used for a long time, the leakage current in the aluminum electrolytic capacitor will increase, reducing the life expectancy. Applying voltage on aluminum electrolytic capacitor allows the electrolyte to have a repairing effect and the leakage current may be reduced.
 - If the product is stored for more than one year, it should be power on for at least 30 minutes without load before use.
 - The contents of the product catalog and user manual are change without prior notice. When using the product, please refer to the latest catalog and user manual.

■ Disclaimer

1.Regardless of whether within the free warranty period or outside the free warranty period, damage caused by reasons that cannot be attributed to our company, damage caused by the company's products, loss of opportunity and loss of profits caused by malfunction, as well as damage caused by special circumstances, whether foreseeable by our company or not. For special condition, UNIFIVE is not responsible for secondary damage, accident compensation, or damage caused to other products or other work.

2.Our products are designed for general industrial equipment and are not suitable for the equipment which acquire highly safety applications (requiring highly reliability and safety, if lack of above characteristics may directly endanger life or health). Although we strive to improve quality and reliability, malfunctions or misoperations may occasionally occur. Therefore, when use our products for high-safety purposes, be sure to adopt necessary fail-safe designs to ensure safety. Please note that UNIFIVE is not responsible for any claims from your or a third party's use of our products for high safety purposes.